

ON-PREMISES RIGID MOUNT WASHER EXTRACTOR

PAN120

120lb

PAN
RANGE

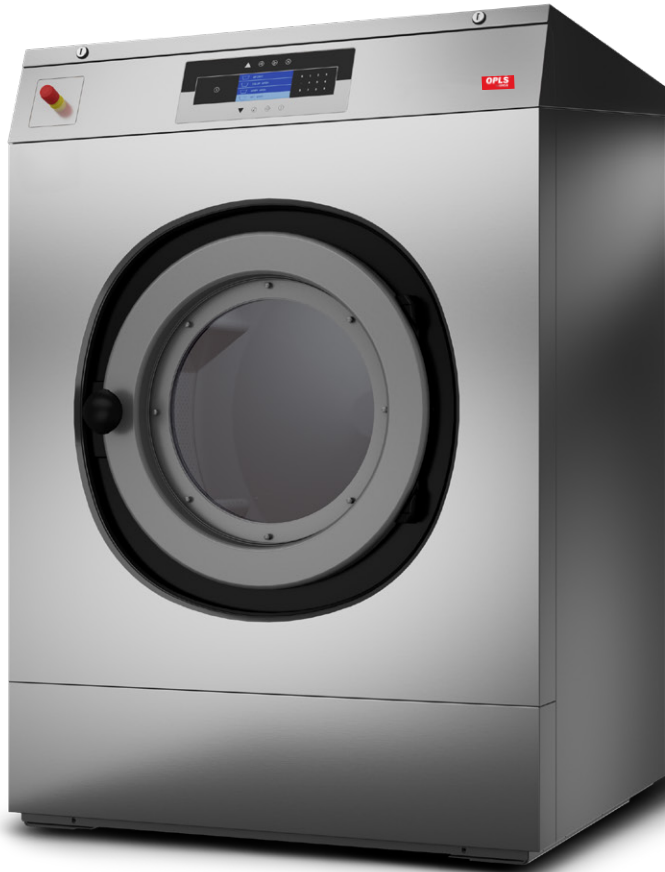

FEATURES

- XControl – fully programmable control
- Large door opening for easy loading and unloading
- Patented Cascade™ cylinder for better washability
- Stainless steel top, front, and side panels
- Stainless steel cylinder and tub
- Rigid mounted, 100 G-Force
- Patented soap hopper
- Large dual drain valve
- Front access to vital parts for easy maintenance
- USB plug on the back panel and control board
- Warranty: First three years on all parts; First five years frame and cylinder shaft assembly; First five years on cylinder bearings and bearing seals (parts only)

OPTIONS

- Third water inlet
- Steam heating

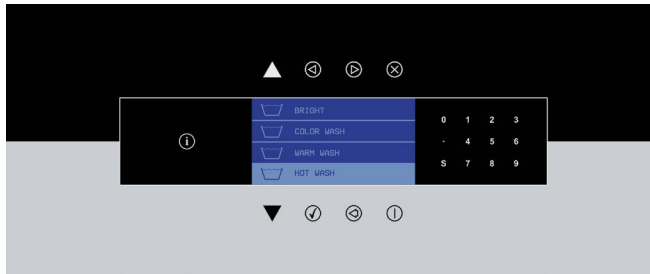

ROBUST DESIGN

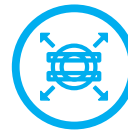

EXTRA LARGE
DOOR



LARGE DRAIN
VALVE CYCLES



3 YEAR PARTS
WARRANTY

Coinamatic™
Commercial Laundry • CCL

Ideas for the future. Answers for today.®

1.877.755.5302 | www.coinamatic.com

MODEL	PAN120	
CONTROL OPTION	XControl+	
CAPACITY - lb (kg)	120 (54)	
OVERALL WIDTH - in (mm)	41.73 (1060)	
OVERALL DEPTH - in (mm)	51.77 (1315)	
OVERALL HEIGHT - in (mm)	59.05 (1500)	
CYLINDER DIAMETER - in (mm)	35.98 (914)	
CYLINDER VOLUME - cu. ft (liters)	18.36 (520)	
DOOR OPENING SIZE - in (mm)	18.31 (465)	
DOOR BOTTOM TO FLOOR - in (mm)	18.31 (465)	
WASH SPEED - RPM	38	
EXTRACT SPEED - RPM	440	
EXTRACT G-FORCE	100	
SOUND PRESSURE LEVEL - dB (A)	< 65	
WATER VALVE CONNECTION - NPT*	1"	
RECOMMENDED WATER PRESSURE - psi	44-73	
WATER INLET (EACH) - g/min	48.34	
DUAL DRAIN VALVE - in (mm)	3 (76)	
FLOW AMOUNT W/ DRAIN VALVE - g/min	110	
FLOOR TO DRAIN OUTLET CENTER - in (mm)	4.72 (120)	
FROM BACK, RIGHT SIDE TO DRAIN OUTLET CENTER - in (mm)	12.52 (318)	
FROM BACK, LEFT SIDE TO DRAIN OUTLET CENTER - in (mm)	10.27 (261)	
VOLTAGE/CIRCUIT BREAKER	200-240/60/1/3**	20-16
- FLA	440-480/60/3	15-9.6
SHIPPING DIMENSIONS	APPROX. - in (mm)	
	Width	43.31 (1100)
	Depth	54.53 (1385)
	Height	66.93 (1700)
NET WEIGHT - lb (kg)	1146 (520)	
SHIPPING WEIGHT - lb (kg)	1257 (570)	
AGENCY APPROVALS	cCSAus	

*Fill hoses provided to convert BSP at machine to NPT supply connection.

**Operates on single or three phase systems as single phase.

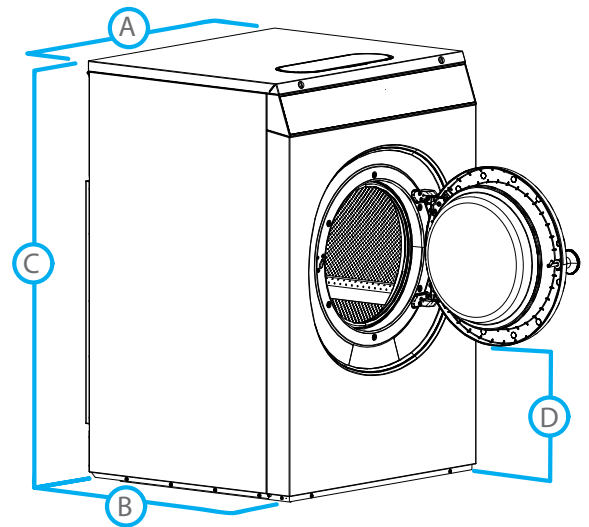

DIMENSIONS	PAN120
A. OVERALL WIDTH - in (mm)	41.73 (1060)
B. OVERALL DEPTH - in (mm)	51.77 (1315)
C. OVERALL HEIGHT - in (mm)	59.05 (1500)
D. DOOR BOTTOM TO FLOOR - in (mm)	18.31 (465)