

QUANTUM® GOLD PREP FOR COIN

COMMERCIAL FRONT CONTROL SINGLE DRYER – STAINLESS – CANADA

Built for Reliable Performance

Huebsch®'s dryer, defined by its simplicity and its performance, provides everything you need to get the job done - and nothing you don't. Huebsch's single load dryers combine heavy-duty construction with reliable operation proven to stand the test of time. They're designed with less moving parts for one reason: so you'll face fewer maintenance problems and less wear and tear down the road. Huebsch's dryers provide the perfect balance of heat, airflow and tumble action for optimal performance and efficiency. Front load products have met every design standard to be 100% ADA compliant.

- Integrated meter case
- Industry's largest door opening 2.06 sq. ft. (1914 cm²)
- Quiet, efficient blower system
- Door is reversible for installation flexibility
- High efficiency exhaust blower with superior airflow 220 cfm (105 liters/sec)
- 100% serviceable from the front
- Space-saving narrow cabinet 26.875" (683 mm)
- Upfront lint filter easy to clean and secured
- Durable galvanized steel cylinder
- Large capacity meter case standard



The cutting edge Quantum® control system from Huebsch gives you the freedom to manage laundry your way with the power to achieve unmatched levels of revenue. Quantum Gold provides users with additional cycle choices while offering new options to help lower operating costs and incorporates tools and options to increase revenue.

SPECIFICATIONS

COMMERCIAL FRONT CONTROL SINGLE DRYER – STAINLESS – CANADA

MODEL - see below for all models and activation available	
CONTROL OPTION	Quantum Gold
COLOR	Stainless
CAPACITY - lb (kg)	18 (8.2)
CYLINDER VOLUME - cu. ft. (liters)	7.0 (198)
MOTOR (THERMAL PROTECTED)	0.33 HP
TYPE OF GAS (GAS MODELS ONLY)	Factory equipped natural
AIR OUTLET DIAMETER - in (mm)	4 (102)
EXHAUST AIRFLOW - cfm (liters/sec)	220 (105)
AVAILABLE CYCLES	High, Medium, Low, Delicates, No Heat
ELECTRICAL REQUIREMENTS	■ Electric 120/240/60/1-30 amp
	Gas 120/60/1-15 amp
HEATING ELEMENT	Electric 5000W, 240V 4250W, 208V
	Gas 25,000 Btu
NET WEIGHT - lb (kg)	Electric 150 (68)
	Gas 150 (68)
SHIPPING WEIGHT - lb (kg)	Electric 161 (73)
	Gas 161 (73)
SHIPPING DIMENSIONS APPROX. - in (mm)	Width 30.5 (775)
	Depth 29.5 (762)
	Height 45 (1143)
AGENCY APPROVALS	Electric cULus
	Gas cCSAus

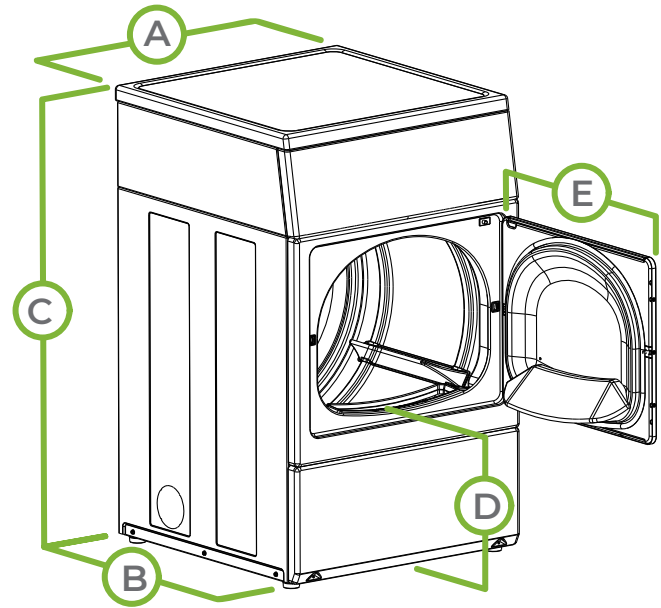

A. OVERALL WIDTH - in (mm)	26.875 (683)
B. OVERALL DEPTH - in (mm)	28 (711)
C. OVERALL HEIGHT - in (mm)	44.34 (1126)
D. FLOOR TO DOOR OPENING - in (mm)	15.44 (392)
E. DOOR SWING - in (mm)	23.5 (597)

MODELS	VOLTAGE/FREQ/PH	ACTIVATION
HDENXAGS173CN01	120/240/60/1	Electric
HDGNXAGS113CN01	120/60/1	Gas

Prep for Coin 

■ Gas dryers can be field converted for operation on LP gas with optional 458P3 conversion kit.

For the most accurate information, the installation guide should be used for all design and construction purposes. Due to continuous product improvements, design and specifications subject to change without notice. The quality management systems at Alliance Laundry Systems are registered to ISO 9001.