

QUANTUM® GOLD COIN DROP INSTALLED

COMMERCIAL REAR CONTROL FRONT LOAD WASHER – CANADA

Built for Reliable Performance

Engineered and built like no other, the Huebsch® front load washer is designed to be everything people thought a washer couldn't be, beginning with its revolutionary suspension and sensing technology. This groundbreaking innovation manages and redistributes out-of-balance loads to deliver uninterrupted cycles, virtually eliminate vibration and operate so quietly neighboring residents won't even know it's running. It also touts an incredible 440 G-Force extraction speed to maximize moisture removal, reduce dry times and minimize utility costs. And as if that's not game-changing enough, this smooth-running, laundry-optimizing machine delivers increased water efficiency. It's everything you never knew it could be.

- Revolutionary balancing technology
- Industry leading 1200 RPM spin speed exerts 440 G-force extraction
- Integrated meter case
- Extra-wide 15.5" door opening and 180° door swing
- Rugged suspension system
- Easy-to-read digital display
- Large capacity meter case standard
- Multi-level vend pricing
- Individual cycle modifier keys
- Durable stainless steel tub standard
- Four-compartment soap dispenser
- Wash Alert™ capability



ENERGY STAR® Certified Washer



The cutting edge Quantum® control system from Huebsch gives you the freedom to manage laundry your way with the power to achieve unmatched levels of revenue. Quantum Gold provides users with additional cycle choices while offering new options to help lower operating costs and incorporates tools and options to increase revenue.

SPECIFICATIONS

COMMERCIAL REAR CONTROL FRONT LOAD WASHER – CANADA

MODEL - see below for all models and activation available	
CONTROL OPTION	Quantum Gold
COLOR	White
CAPACITY - lb (kg)	21.5 (9.5)
OVERALL WIDTH - in (mm)	26.875 (683)
OVERALL DEPTH - in (mm)	27.73 (704)
OVERALL HEIGHT - in (mm)	43.875 (1114)
CYLINDER VOLUME - cu. ft. (liters)	3.42 (96.8)
SPIN SPEED G-FORCE (RPM)	440 (1200)
MOTOR SIZE - HP (kw)	0.9 (0.67)
WATER CONSUMPTION PER CYCLE - g (liter)	13.68 (51.8)
IWF (WATER FACTOR) - gal/ft ³ (liters/liter/cycle)	4.0 (0.53)
MEF ₁₂ (Modified Energy Factor) ft ³ /kWh/cycle (Liters/kWh/cycle)	2.20 (62.3)
AVAILABLE WATER TEMPERATURES	Hot, Warm, Cold
AVAILABLE CYCLES	Normal, Perm Press, Delicates/Bulky
ELECTRICAL REQUIREMENTS (v/Hz/Ph-Amp)	120/60/1 - 15 Amp
WATER PRESSURE - p.s.i. (bar)	20-120 (1.4/8.3)
DRAIN	Pump
CYLINDER FINISH	Stainless Steel
NET WEIGHT - lb (kg)	260 (118)
SHIPPING WEIGHT - lb (kg)	270 (122.2)
SHIPPING DIMENSIONS APPROX. - in (mm)	Width 34 (864)
	Depth 30 (762)
	Height 44.5 (1130)
AGENCY APPROVALS	cULus

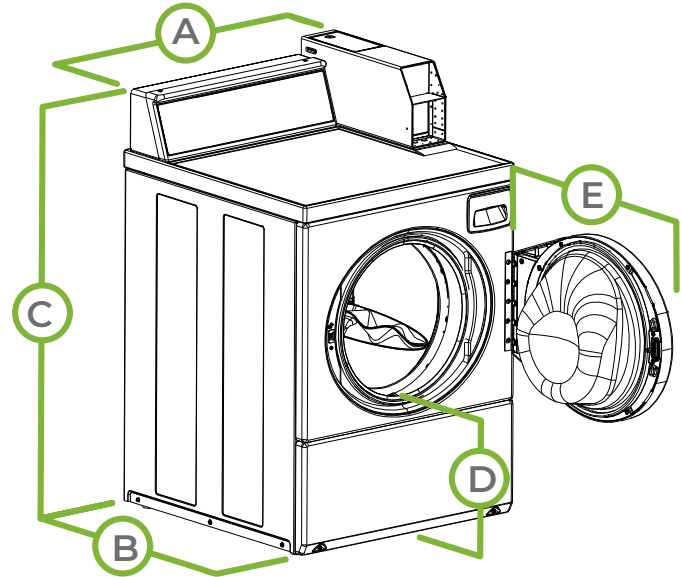

A.	OVERALL WIDTH - in (mm)	26.875 (683)
B.	OVERALL DEPTH - in (mm)	27.73 (704)
C.	OVERALL HEIGHT - in (mm)	43.875 (1114)
D.	FLOOR TO DOOR OPENING -in (mm)	14.6 (371)
E.	DOOR SWING - in (mm)	24 (610)

MODELS	ACTIVATION
HFNNERSP115CW01	Coin Drop Installed 

For the most accurate information, the installation guide should be used for all design and construction purposes. Due to continuous product improvements, design and specifications subject to change without notice. The quality management systems at Alliance Laundry Systems are registered to ISO 9001.