

# HUEBSCH MULTI-HOUSING

## ELECTRONIC HOMESTYLE

# COMMERCIAL FRONT CONTROL SINGLE DRYER – CANADA

## Built for Reliable Performance

Huebsch® single load dryers are durably constructed using premium materials for long-lasting, reliable performance and superior wash results. If you want your laundry done right, you want a Huebsch. Our machines are manufactured using metal instead of plastic. They're built with rugged, commercial-grade construction and pushed beyond their limit in our state-of-the-art test lab, ensuring unmatched durability. Our world-class test lab rigorously pushes our products far beyond the conditions they're likely to ever face. We work hard at every point of our manufacturing process to ensure that our machines reflect that belief. Front load products have met every design standard to be 100% ADA compliant.

- Industry's largest door opening 2.06 sq. ft. (1914 cm<sup>2</sup>)
- Door is reversible for installation flexibility
- High efficiency exhaust blower with superior airflow 220 cfm (105 liters/sec)
- 100% serviceable from the front
- Space-saving narrow cabinet 26.875" (683 mm)
- Upfront lint filter easy to clean and secured
- Durable galvanized steel cylinder
- Efficient and fast dry cycle
- Extra-large capacity

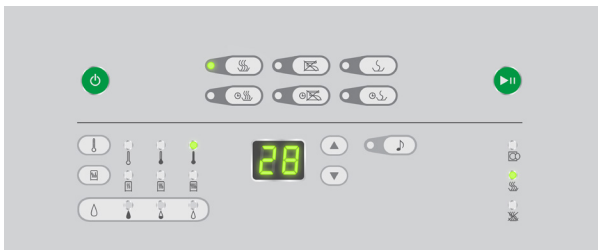

Electronic homestyle control is designed for durability and easy operation with attractive selection buttons and cycle status indicator lights.

SPECIFICATIONS

# COMMERCIAL FRONT CONTROL SINGLE DRYER – CANADA

MODEL - see below for all models and activation available	
CONTROL OPTION	Electronic Homestyle
COLOR	White
CAPACITY - lb (kg)	18 (8.2)
CYLINDER VOLUME - cu. ft. (liters)	7.0 (198)
MOTOR (THERMAL PROTECTED)	0.33 HP
TYPE OF GAS (GAS MODELS ONLY)	Factory equipped natural/mixed gas
AIR OUTLET DIAMETER - in (mm)	4 (102)
EXHAUST AIRFLOW - cfm (liters/sec)	220 (105)
AVAILABLE CYCLES	Regular, Permanent Press, Delicate, Time Dry, Quick Dry, Fluff Up
ELECTRICAL REQUIREMENTS	■ Electric 120/240/60/1-30 amp 120/208/240/60/1-30 amp
	Gas 120/60/1-15 amp
HEATING ELEMENT	Electric 5000W, 240V
	Gas 22,500 Btu
NET WEIGHT - lb (kg)	Electric 126 (57.2)
	Gas 130 (59)
SHIPPING WEIGHT - lb (kg)	Electric 136 (61.7)
	Gas 140 (63.5)
SHIPPING DIMENSIONS APPROX. - in (mm)	Width 30.5 (775)
	Depth 29.5 (762)
	Height 45 (1143)
AGENCY APPROVALS	Electric cULus
	Gas cCSAus

MODELS	VOLTAGE/FREQ/PH	
YDEE5BGS173CW01	208-240/60/1	Electric
YDGE5BGS113CW01	120/60/1	Gas

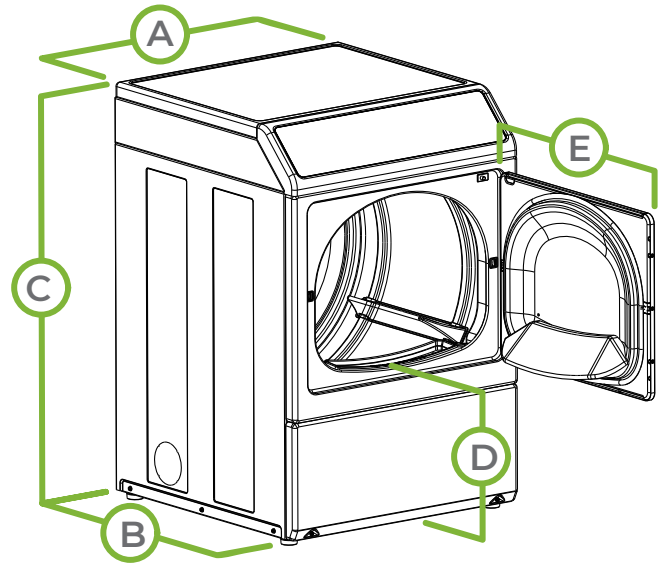

A. OVERALL WIDTH - in (mm)	26.875 (683)
B. OVERALL DEPTH - in (mm)	28 (711)
C. OVERALL HEIGHT - in (mm)	40.42 (1027)
D. FLOOR TO DOOR OPENING - in (mm)	15.44 (392)
E. DOOR SWING - in (mm)	23.5 (597)

■ Gas dryers can be field converted for operation on LP gas with optional 458P3 conversion kit.

For the most accurate information, the installation guide should be used for all design and construction purposes. Due to continuous product improvements, design and specifications subject to change without notice. The quality management systems at Alliance Laundry Systems are registered to ISO 9001.