

# OPLS™

by WASH

ON-PREMISE LAUNDRY SOLUTIONS

# Hardmount Washer-Extractor

## PAN055

55 lb (24 kg)



### FEATURES

- High speed spin up to 200G
- Patented Cascade Drum™
- Stainless steel top, front and side panels
- Stainless steel drum and tub
- Easy Soap™ - liquid soaps connection
- Large door opening for easy loading unloading
- Soap hopper

### XCONTROL+

- Fully programmable
- 20 preset programs, up to 99 in memory



ERGONOMIC  
CONSTRUCTION



LARGE DOOR  
OPENING



LOW WATER  
AND ENERGY  
CONSUMPTION

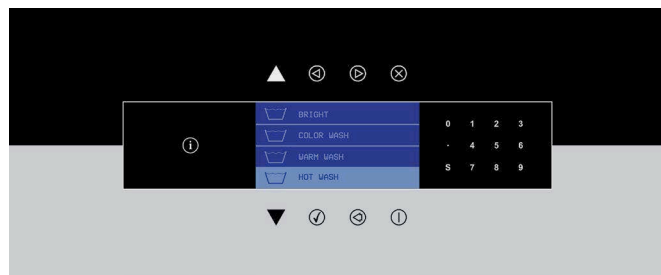

# CCL

COMMERCIAL LAUNDRY EQUIPMENT  
A Coinmatic Company

*Ideas for the future. Answers for today.®*

1.877.755.5302 | [www.cclcommerciallaundry.com](http://www.cclcommerciallaundry.com)

# Hardmount Washer-Extractor

## Specifications

		PAN055
CONTROL OPTION		X Control+
CAPACITY - lb (kg)		55 (24)
OVERALL WIDTH - in (mm)		35.03 (890)
OVERALL DEPTH - in (mm)		41.73 (1060)
OVERALL HEIGHT - in (mm)		55.51 (1410)
CYLINDER DIAMETER - in (mm)		29.53 (750)
CYLINDER VOLUME - cu. ft. (liters)		8.5 (241)
DOOR OPENING SIZE - in (mm)		18.11 (460)
DOOR BOTTOM TO FLOOR - in (mm)		18.31 (465)
WASH SPEED - RPM		42
EXTRACT SPEED - RPM		690
EXTRACT G-FORCE		200
STEAM HEATING - psi		15-116
SOUND PRESSURE LEVEL - dB (A)		< 65
WATER VALVE CONNECTION - NPT*		0.75"
WATER PRESSURE -psi		15-116
RECOMMENDED WATER PRESSURE - psi		44-73
WATER INLET (EACH) - g/min		5.28
DRAIN VALVE - in (mm)		3 (76)
FLOW AMOUNT W/ DRAIN VALVE - g/min		55.48
FLOOR TO DRAIN OUTLET CENTER - in (mm)		5.12 (130)
SIDE TO DRAIN OUTLET CENTER - in (mm)		11.02 (280)
STEAM VALVE CONNECTION - BSP		0.5"
VOLTAGE/CIRCUIT BREAKER - FLA 208-240/60/1		15-9.2
SHIPPING DIMENSIONS APPROX. - in (mm)	Width	36.42 (925)
	Depth	44.49 (1130)
	Height	61.02 (1550)
NET WEIGHT - lb (kg)		728 (330)
SHIPPING WEIGHT - lb (kg)		783 (355)
AGENCY APPROVALS		CSA

\*Fill hoses provided to convert BSP at machine to NPT supply connection.

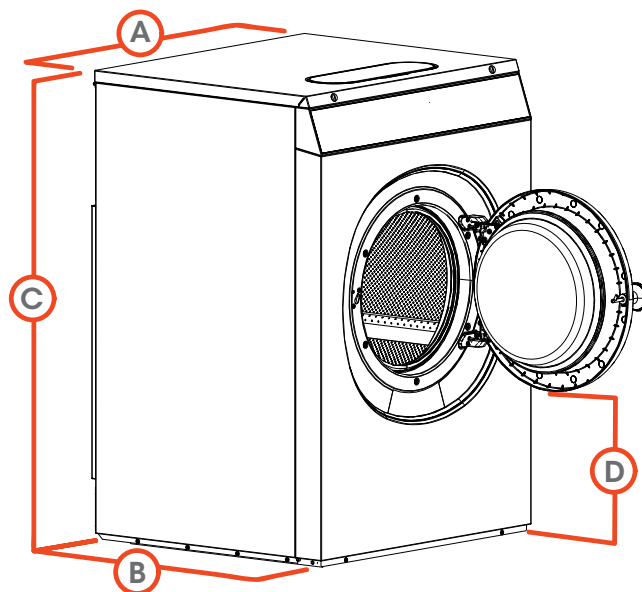

A. Overall Width - in (mm)	35.03 (890)
B. Overall Depth - in (mm)	41.73 (1060)
C. Overall Height - in (mm)	55.51 (1410)
D. Door Bottom to Floor - in (mm)	18.31 (465)

For the most accurate information, the installation guide should be used for all design and construction purposes. Due to continuous product improvements, design and specifications subject to change without notice. The quality management systems at Alliance Laundry Systems are registered to ISO 9001. 2023 Specifications

OPLS by WASH is manufactured by Alliance Laundry Systems LLC



*Ideas for the future. Answers for today.®*

1.877.755.5302 | [www.cclcommerciallaundry.com](http://www.cclcommerciallaundry.com)