

# ON-PREMISES PREMIUM SINGLE TUMBLE DRYER

PT030

30lb



## FEATURES

- Easy-to-use digital control
- Electric, gas and steam heating
- Large door opening for easy loading and unloading
- Galvanized cylinder
- Axial airflow
- Large self-cleaning lint screen
- Fits through 36" door opening

## OPTIONS

- Reversing cylinder to avoid tangling of large items
- Stainless steel cylinder
- Stainless steel front panel
- Sensodry+<sup>®</sup> over-dry prevention technology lowers energy, utility and linen replacement costs
- SafeTech<sup>™</sup> Fire Suppression System, a multi-port water manifold system, will saturate linens in an unlikely event of fire within the cylinder



FAST DRYING



EASY OPERATION



SERVICE FRIENDLY

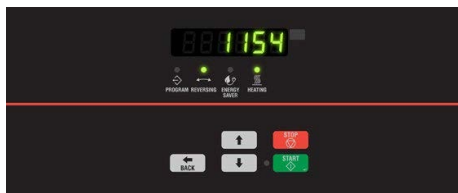

XQ Control

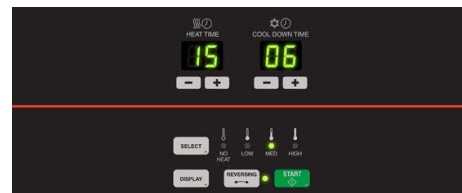

Dual Digital Control

<b>MODEL</b>		PT030	
CONTROL OPTION		XQ, DDC	
CAPACITY - lb (kg)		30 (14)	
OVERALL WIDTH - in (mm)		28 (711)	
OVERALL DEPTH - in (mm)		46.87 (1190)	
OVERALL HEIGHT - in (mm)		63.87 (1622)	
CYLINDER DIAMETER - in (mm)		26.5 (673)	
CYLINDER VOLUME - cu. ft (liters)		9.6 (272)	
DOOR OPENING SIZE - in (mm)		22.69 (576)	
ENERGY DATA	Steam Models - 100 psi	134,700 Btu/hr	
	Electric Models	21 kW	
EXHAUST - in (mm)		6 (152)	
GAS CONNECTIONS - in (npt)		0.5	
STEAM CONNECTIONS - in (npt)		0.75	
MOTOR - hp	Fan	0.25	
	Drive	0.25	
DRYING AVERAGE - lbs/min	Gas Heating	0.57	
	Electric Heating	0.6	
AIRFLOW - cfm		500	
ELECTRIC SPECS - amps		Non Rev (Rev)	
GAS & STEAM	100/200-220/60/1 2W+G	11.0/5.8	
	120/208-240/60/1 2W/3W+G	12.0/6.7	
	200-208/240/60/3 3W+G	3.2/3.2 (4.0/4.0)	
	380/60/3 3W+G	1.5 (2.0)	
	440/60/3 3W+G	1.6 (2.0)	
	460-480/60/3 3W+G	1.6 (2.0)	
	ELECTRIC	208/60/1 3W+G	108
		240/60/1 3W+G	94
200/60/1 2W+G		108	
200-208/60/3 3W+G		62 (62)	
240/60/3 3W+G		54 (54)	
380/60/3 3W+G		33 (33)	
440/60/3 3W+G		29 (29)	
460-480/60/3 3W+G		27 (27)	
SHIPPING DIMENSIONS - in (mm)	APPROX. Width	30 (762)	
	Depth	49 (1245)	
	Height	69 (1753)	
NET WEIGHT - lb (kg)		330 (150)	
SHIPPING WEIGHT - lb (kg)		364 (165)	
AGENCY APPROVALS		cCSAus	

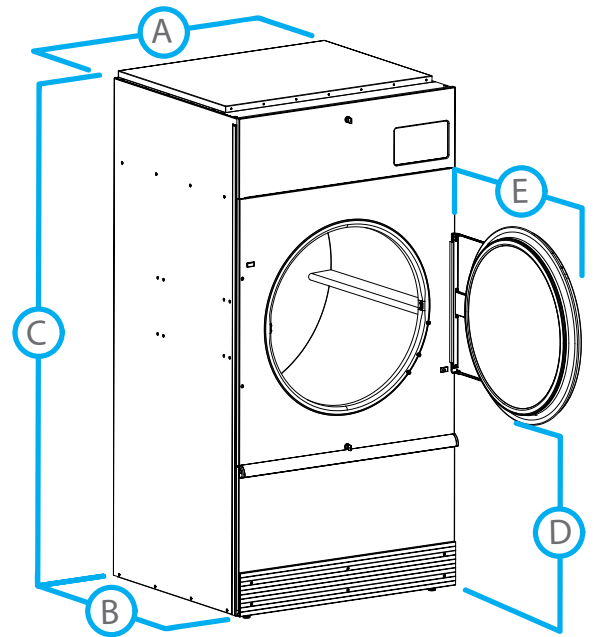

DIMENSIONS		PT030
A.	OVERALL WIDTH - in (mm)	28 (711)
B.	OVERALL DEPTH - in (mm)	46.87 (1190)
C.	OVERALL HEIGHT - in (mm)	63.87 (1622)
D.	DOOR BOTTOM TO FLOOR - in (mm)	27.5 (669)
E.	DOOR SWING - in (mm)	26.25 (667)