

HUEBSCH MULTI-HOUSING

QUANTUM® GOLD PRO PREP FOR CARD, PREP FOR COIN COMMERCIAL TOP LOAD WASHER – CANADA

Built for Reliable Performance

Huebsch®'s two-speed top load washer, defined by its simplicity and its performance, provides everything you need to get the job done – and nothing you don't. Huebsch's top load washer combines heavy-duty construction with reliable operation proven to stand the test of time. Huebsch® washers provide maximum energy efficiency and long-lasting performance.

- Touch pad control with sound annunciator
- 27 cycle selections
- Extract speed of 710 RPM spins clothes out drier
- Integrated meter case
- Advanced suspension system
- Easy-to-read digital display
- Cycle programming flexibility
- Multi-level vend pricing
- Individual cycle modifier keys
- Durable stainless steel tub standard
- 3.19 cu. ft. (90.3 liters) wash capacity
- Large capacity meter case standard
- Wash Alert™ capability

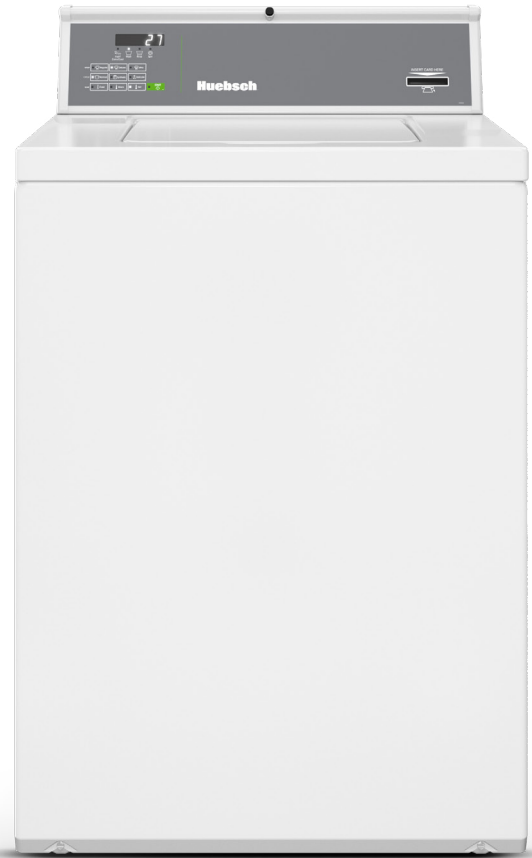

The Quantum® Gold Pro control delivers a truly premium experience to residents. From intuitive soft touch buttons that walk them through cycle options to multiple actuations (coin, card, mobile) for payment flexibility, this control gives residents the wash and dry options they want, and the revenue potential managers desire.





SPECIFICATIONS

COMMERCIAL TOP LOAD WASHER – CANADA

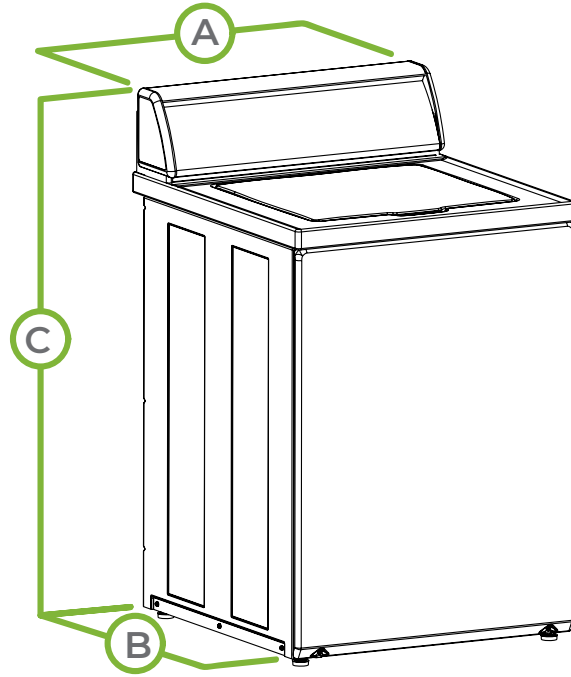
MODEL - see below for all models and activation available		
CONTROL OPTION	Quantum Gold Pro	
COLOR	White	
CAPACITY - lb (kg)	16 (7.3)	
OVERALL WIDTH - in (mm)	25.63 (651)	
OVERALL DEPTH - in (mm)	28 (711)	
OVERALL HEIGHT - in (mm)	43 (1092)	
CYLINDER VOLUME - cu. ft. (liters)	3.19 (90.3)	
SPIN SPEED G-FORCE (RPM)	150 (710)	
MOTOR SIZE - HP (kw)	0.5 (0.37)	
WATER CONSUMPTION PER CYCLE - g (liter)**	28.07 (106)	
IWF (WATER FACTOR) - gal/ft ³ (liters/liter/cycle)**	8.8 (1.18)	
MEF ₃₂ (Modified Energy Factor) ft ³ /kWh/cycle (Liters/kWh/cycle)**	1.35 (38.2)	
AVAILABLE WATER TEMPERATURES	Cold, Warm, Hot	
AVAILABLE CYCLES	Normal, Synthetic, Delicate	
ELECTRICAL REQUIREMENTS (v/Hz/Ph-Amp)	120/60/1 - 15 Amp	
WATER PRESSURE - p.s.i. (bar)	20-120 (1.4/8.3)	
DRAIN	Pump	
CYLINDER FINISH	Stainless Steel	
NET WEIGHT - lb (kg)	206 (93.4)	
SHIPPING WEIGHT - lb (kg)	218 (98.8)	
SHIPPING DIMENSIONS APPROX. - in (mm)	Width	28 (711)
	Depth	30 (762)
	Height	45 (1143)
AGENCY APPROVALS	cULus	



A.	OVERALL WIDTH - in (mm)	25.625 (651)
B.	OVERALL DEPTH - in (mm)	28 (711)
C.	OVERALL HEIGHT - in (mm)	43 (1092)

MODELS	ACTUATION
HWNNX2SP116CW01	Prep for Coin 
HWNNY2SP116CW01	Prep for Card 

** Average usage based on multiple load sizes and current DOE test protocol. Real usage will vary depending on load size, composition and cycle selectivity.

For the most accurate information, the installation guide should be used for all design and construction purposes. Due to continuous product improvements, design and specifications subject to change without notice. The quality management systems at Alliance Laundry Systems are registered to ISO 9001.